

SIZE870 ROTARY SOLENOID

UNIT : $\frac{\text{mm}}{\text{(inch)}}$
 SHOWN DE-ENERGIZED, RIGHT HAND ROTATION

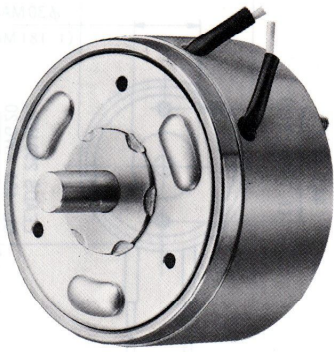

WEIGHT (ABD&R) : 1,885g

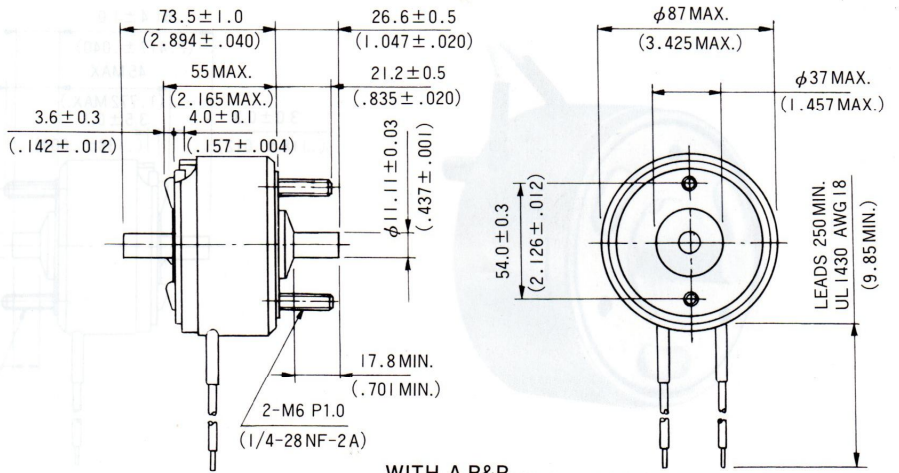

WITH A,B&R

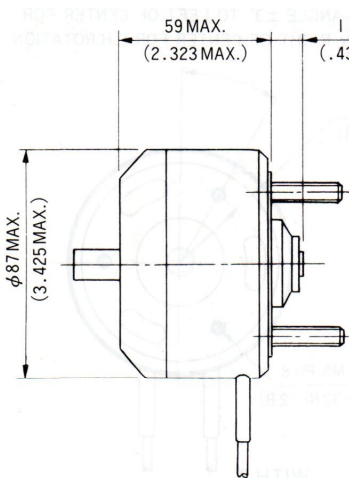

WITH A,D&R

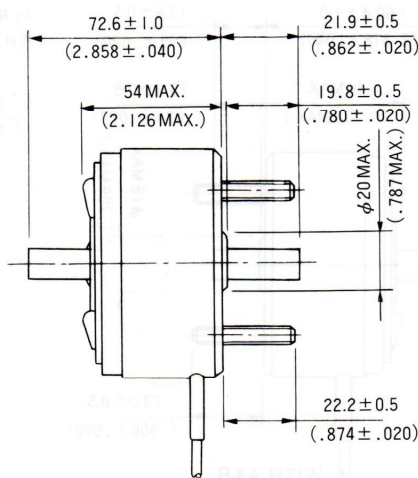

WITH A&B

1/2 ROTATION ANGLE ± 3° TO LEFT OF CENTER FOR R.H. ROTATION, RIGHT OF CENTER FOR L.H. ROTATION.

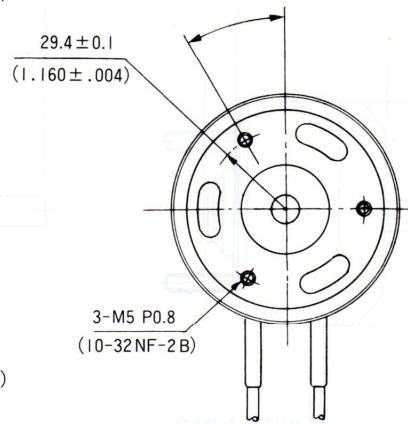

WITH T

COIL DATA

Heat sink : 520×520×3mm aluminum

Return spring torque : 0.09~0.14 N·m

duty cycle = $\frac{\text{"on" time}}{\text{"on" time} + \text{"off" time}} \times 100\%$			100% continuous	75% or less	50% or less	25% or less	10% or less	
MAX. "on" time in seconds			∞	85	72	43	20	
watts at 20°C			41	54.5	82	164	410	
ampere-turns at 20°C			1910	2190	2750	3810	5950	
gross starting torque at 20°C (N·m)			25°	1.84	2.65	4.25	6.9	11.3
			35°	1.38	1.84	2.76	4.5	7.35
			45°	1.15	1.5	2.2	3.9	6.2
			67.5°	0.48	0.69	1.15	1.95	3.34
			95°	0.4	0.48	0.7	1.15	1.95
AWG no.	resistance Ω ± 10% (at 20°C)	no. turns	volts DC					
18	1.47	368	7.6	8.7	11	15	24	
19	2.3	459	9.6	11	14	19	30	
20	3.64	580	12	14	17	24	37	
21	5.57	704	15	17	22	30	47	
22	9.5	936	19	22	28	39	60	
23	14.3	1134	24	28	35	48	75	
24	23.3	1456	30	35	44	61	95	
25	37.1	1836	39	44	56	77	120	
26	58.6	2300	49	56	70	97	152	
27	89.8	2816	61	70	88	121	189	
28	139	3456	76	88	111	153	239	
29	227	4480	98	111	138	193	300	
30	376	5792	124	143	177	248	387	
31	515	6600	148	170	212	297	—	
32	785	7850	188	220	275	385	—	
33	1130	9050	237	271	339	—	—	